

PyroCouple, PyroEpsilon, PyroBus, PyroCAN

General Purpose Infrared Temperature Sensors



shown actual size

- Temperature range: -20°C to 500°C
- Choice of precision optics for large or small targets at short or long distances
- Fast response with high stability
- Stainless steel housing, sealed to IP65
- Quick and easy installation
- Wide range of accessories

The Calex Compact Series is a range of high quality, low cost non-contact sensors that measure the temperature of inaccessible or moving objects and materials. They measure temperatures from -20°C to 500°C, accurately and consistently, with an outstanding response time of 240 ms. All models conform to industrial EMC standards.



PyroCouple with indicator



PyroEpsilon with PyroTune emissivity adjuster



PyroBus sensors with PM180 touch screen display



PyroCAN Sensor with CAN Bus Interface

The **PyroCouple** is a simple infrared temperature sensor with a choice of analogue outputs. No complicated setup is required - just connect a temperature indicator and power supply, and instantly start taking measurements.

- Temperature ranges from -20°C to 500°C
- Suitable for non-contact temperature measurement on most non-reflective non-metal surfaces, such as paper, thick plastics, asphalt, painted surfaces, food, rubber and organic materials, among many others.
- Choice of analogue outputs for measured temperature:
 - Two-wire 4-20 mA,
 - Four-wire 0-50 mV,
 - Four-wire Type K, J or T thermocouple
- Additional sensor body temperature output on four-wire models: indicates the air temperature around the sensor and helps prevent overheating or overcooling

The **PyroEpsilon** is a simple sensor with an adjustable emissivity setting. It is ideal if the target is partially reflective.

- Temperature ranges from -20°C to 500°C
- Two-wire 4-20 mA output
- Emissivity adjustment via a separate two-wire 4-20 mA input
- Adjust the emissivity continuously during the process using a variable 4-20 mA source
- Set the emissivity manually with the PyroTune emissivity adjuster
- If you are not sure the emissivity of the target is high, choose the PyroEpsilon instead of the PyroCouple.

The **PyroBus** is a networkable, fully configurable sensor with RS485 Modbus RTU communications.

- Temperature ranges from -20°C to 500°C
- Up to 247 sensors may be connected to a single network.
- Adjustable emissivity setting for use on a wide range of materials
- Averaging function to smooth the temperature output
- Peak and valley hold processing for measuring individual objects on a conveyor
- Reflected energy compensation for accurately measuring the temperature of objects in ovens or chillers, from outside
- Optional 6-channel touch screen terminal for local display, configuration and data logging
- Connect sensors and 6-channel terminals directly to an existing RS485 Modbus system

The **PyroCAN** is a sensor with CAN communications.

- Temperature range: -20°C to 1000°C
- Raw CAN communications
- Adjustable emissivity setting for measuring a variety of materials
- Ideal for onboard vehicle temperature monitoring, and many other applications
- Conforms with EMC standard EN 13309:2010

GENERAL SPECIFICATIONS - SENSORS

Output (PyroCouple)

PyroCouple Output Option (see Model Numbers)	Target Temperature Output	Sensor Temperature Output
-0	4-20 mA	Not available
-1	0-50 mV	4-20 mA
-2	Type T thermocouple	4-20 mA
-3	Type J thermocouple	4-20 mA
-4	Type K thermocouple	4-20 mA
-5	0-50 mV (very low current draw: 3.2 mA)	Not available

	PyroCouple	PyroEpsilon	PyroBus	PyroCAN
Output	See Above	Two-wire 4-20 mA	RS485 Modbus RTU	Raw CAN
Temperature Range	LT = -20 to +100 °C MT = 0 to 250 °C HT = 0 to 500 °C		-20 to 500°C	-20°C to 1000°C
Accuracy	±1% of reading or ±1°C whichever is greater			
Repeatability	± 0.5% of reading or ± 0.5°C whichever is greater			
Emissivity Setting	Fixed at 0.95	Variable 0.2 to 1.0 via continuous 4-20 mA input	Adjustable 0.2 to 1.0 via RS485 Modbus	Adjustable 0.2 to 1.0 via CAN
Response Time	240 ms (90% response)			200 ms (90% response)
Spectral Range	8 to 14 µm			
Supply Voltage	24 V DC (28 V DC max.)		12 V DC (13 V DC max.)	24 V DC (28 V DC max)
Min. Sensor Voltage	6 V DC			12 V DC
Max. Loop Impedance	900 Ω (4-20 mA output)		-	
Output Impedance	56 Ω (voltage/thermocouple output)	-		
Input Impedance	-	50 Ω	-	
Current Draw	20 mA max. (PyroCouple -5 models: 3.2 mA @ 24 V DC)		50 mA max	
Baud Rate	-		9600 bps	250 kbps*
Format	-		8 data bits, no parity, 1 stop bit *	-

* Other configurations available upon request

MECHANICAL

	PyroCouple	PyroEpsilon	PyroBus	PyroCAN
Construction	Stainless Steel			
Dimensions	18 mm diameter x 103 mm long			
Thread Mounting	M16 x 1 mm pitch			
Cable Length	1m (longer lengths available to order)			
Weight with Cable	95 g			

ENVIRONMENTAL

	PyroCouple	PyroEpsilon	PyroBus	PyroCAN
Construction	IP65			
Dimensions	0°C to 70°C			0°C to 90°C
Thread Mounting	95% max. non-condensing			

PYROCAN

Example data message received from sensor:

Object Temperature				Ambient Temperature					
Bytes	DLC	DATA0	DATA1	DATA2	DATA3	DATA4	DATA5	DATA6	DATA7
Value	8	0x51	0x39	0xB2	0x41	0xA4	0x70	0xDF	0x41
Hex		0x41B23951				0x41DF70A4			
Encoding		Float				Float			
Decimal		22.28 °C				27.93 °C			

PYROTUNE

GENERAL SPECIFICATIONS	
Output	4-20 mA for emissivity adjustment of PyroEpsilon sensor
Supply Voltage	24 V DC (13 V to 28 V DC)
Display Format	3.5 digit LCD
Display Units	Emissivity (0.2 to 1.0) or current (4 - 20 mA)
Adjustment	Push-buttons (raise/lower/set)
MECHANICAL	
Construction screws	Polycarbonate with gasket, transparent lid (PC) and quick release
Mounting	Surface
Dimensions	65 mm tall x 50 mm wide x 35 mm deep
Weight	72 g
ENVIRONMENTAL	
Environmental Rating	IP65
Ambient Temperature Range	0°C to 70°C
Relative Humidity	95% max. non-condensing

PYROCOUPLE

Two-wire (option 0)

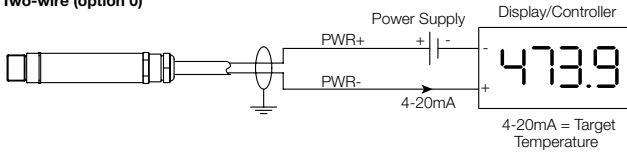

Output types 1 to 4 only (optional)

Four-wire (options 1 to 5)

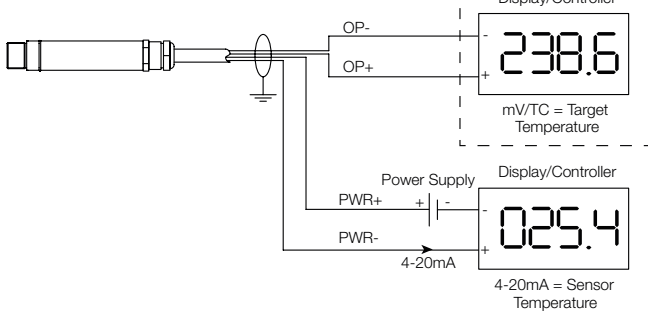

PYROEPSILON

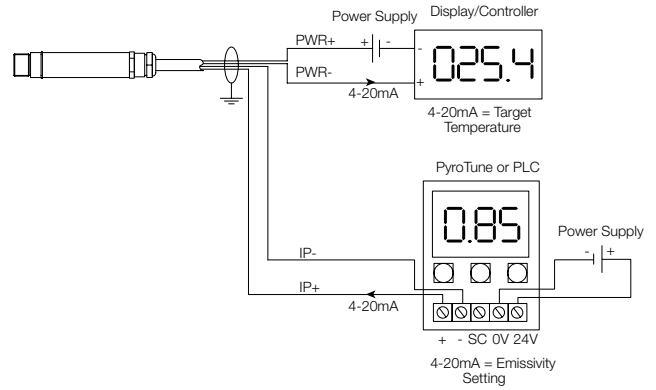

PYROBUS

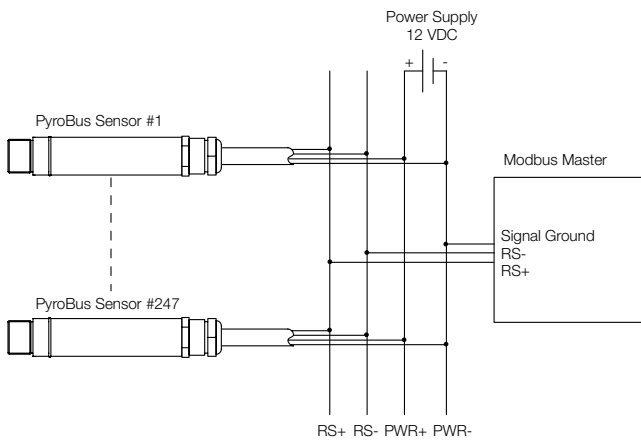

PYROCAN

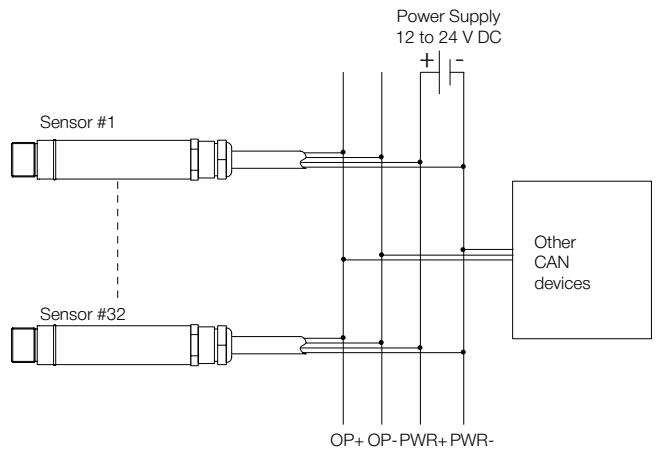

OPTICS

Diameter of target spot measured versus distance from sensing head (90% energy)

Optics available for PyroCouple, PyroEpsilon, PyroBus

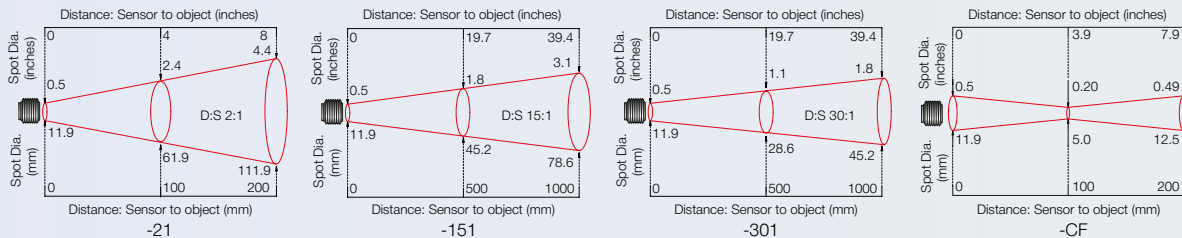

Optics available for PyroCAN

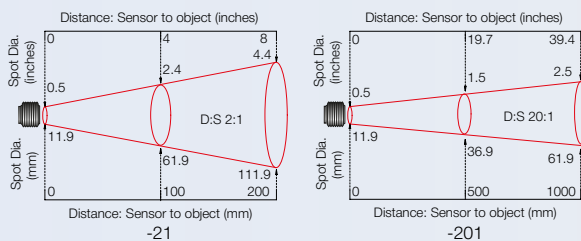

ACCESSORIES



Fixed mounting bracket **FBS**



Air purge collar for 2:1 optics **APSW**
or for all other optics (shown above) **APSN**



Laser sighting tool **LSTS**



Adjustable mounting bracket **ABS**



Air or water cooled jacket with air purge collar **WJ** (see Model Numbers)



Dual laser sighting bracket, adjustable **DLSBAS** or fixed **DLSBFS**



PyroTune emissivity adjuster **PT**
(for PyroEpsilon only)



6-channel touch screen interface for temperature display, configuration and data logging (PyroBus only) **PM180**



Protective plastic window with stainless steel holder **PWS**
(not compatible with PyroCouple)

MODEL NUMBERS



Cooling
(blank) = Sensor without cooling
WJ = Air/water cooled jacket with air purge collar

Output option (PyroCouple only)
0 = 2 wire, 4-20mA
1 = 4-wire, 0-50mV (target temp.), 4-20mA (sensor temp.)
2 = 4-wire, T Thermocouple (target temp.), 4-20mA (sensor temp.)
3 = 4-wire, J Thermocouple (target temp.), 4-20mA (sensor temp.)
4 = 4-wire, K Thermocouple (target temp.), 4-20mA (sensor temp.)
5 = 4-wire, 0-50 mV (target temp.), very low current draw

e.g. Model PC151HT-4 has a type K thermocouple output representing target temperatures of 0°C to 500°C plus a 4-20 mA output proportional to internal sensor temperature. For simplicity, the sensor temperature range is always set the same as the target temperature range

Temperature range (PyroCouple and PyroEpsilon only)
LT = -20 to +100 °C
MT = 0 to 250 °C
HT = 0 to 500 °C (not normally available on PC21 models)

Field of view
21 = 2:1 divergent optics
151 = 15:1 divergent optics
301 = 30:1 divergent optics
CF = Close-focus optics (focal spot size 5 mm at 100mm distance)
201 = 20:1 general-purpose divergent optics (PCAN series only)
Note: PyroCAN sensors are available with 2:1 and 20:1 optics only

Series
PC = PyroCouple: fixed emissivity, choice of analogue outputs
PE = PyroEpsilon: adjustable emissivity, 4-20 mA output
PB = PyroBus: fully configurable, RS485 Modbus communications
PCAN = PyroCAN: Adjustable emissivity, CAN Bus communications

Example Model Numbers: PC151MT-0, PE151MT, PB151, PCAN201